

RUNTAL HOT HOOP

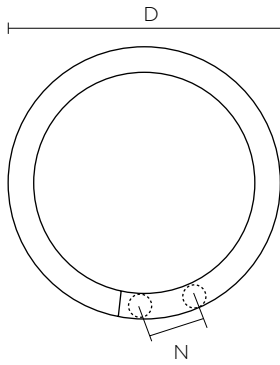

runtal

RUNTAL HOT HOOP



FRONT VIEW

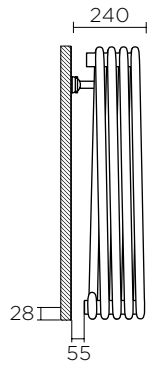

SIDE VIEW

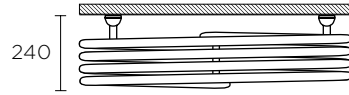

TOP VIEW

- D Diameter (mm)
- N Pipe centres (mm)
- Connections at back side of radiator

Diameter 500mm	N mm	V dm ³	M kg	n	P ΔT 50K Watt	Surface (Code)
HHR-050-050	50	4.6	12	1.27	402	RAL9016 (0603)
HHR-050-050-ML	50	4.6	12	1.27	402	Metallica (0434)

Diameter 700mm	N mm	V dm ³	M kg	n	P ΔT 50K Watt	Surface (Code)
HHR-070-070	50	6.5	17	1.27	581	RAL9016 (0603)
HHR-070-070-ML	50	6.5	17	1.27	581	Metallica (0434)

Diameter 900mm	N mm	V dm ³	M kg	n	P ΔT 50K Watt	Surface (Code)
HHR-090-090	50	8.2	21	1.27	760	RAL9016 (0603)
HHR-090-090-ML	50	8.2	21	1.27	760	Metallica (0434)

N: pipe centres, V: volume, M: weight, n: exponent, PΔT 50K: EN442 output

TECHNICAL DATA

Materials	Flat steel tube 49x26mm forming an oval shape, powder-coated in white RAL9016 (0603) or metallica (0434)
Operating pressure	Max. 8.0 bar
Test pressure	12.0 bar
Operating temperature	Max. 90 °C
Standard kit	Brackets in the same finish as the radiator, screws and plugs, ¼" air vent included in the packaging
Connections	With the standard Ø ½" connections with internal thread, the following types of connections are possible. ½" flow ►/return ◄ at choice left- or right-hand at the bottom back side at the same height on either side, Ø ¼" air vent (E)

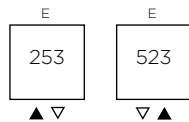

Single pipe systems Not possible

Valves

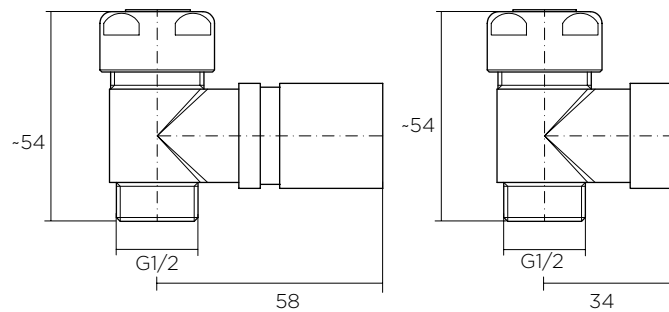

Runtal Hotval Kit

Code HOTVAL-KIT-790

Kit includes

HOTVAL chrome valve kit with straight radiator valve (TRV) with head and lockshield valve (LSV), pair of fittings for Ø 12/14 copper pipe, pair of fittings for Ø 14-10/16-12 multilayer pipe.
For pipe fittings other than those provided, please refer to the valves prices list

RUNTAL HOT HOOP MOUNTING INSTRUCTIONS

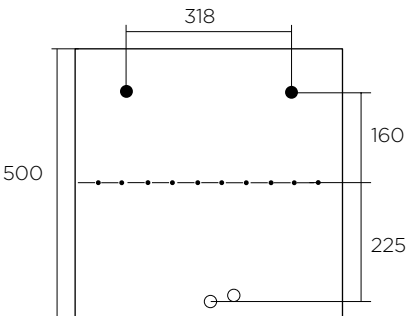

HHR-050-50

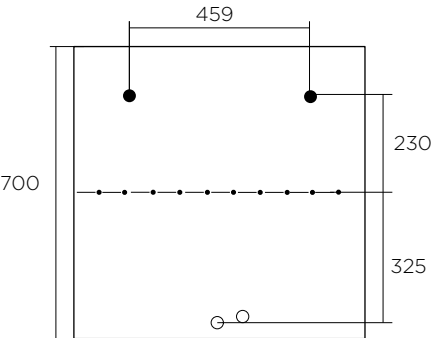

HHR-070-070

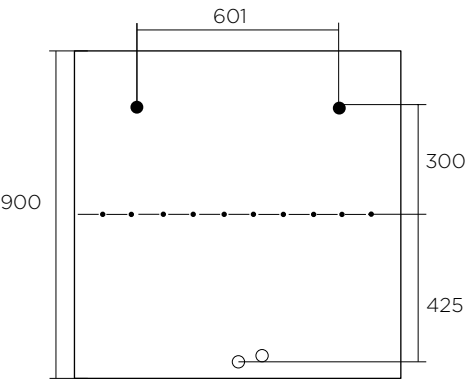

HHR-090-90

- Fixing point
- Pipe centres

For correct installation, please note the corresponding installation instructions

ZEHNDER GROUP INTERNATIONAL SALES

Almweg 34, DE-77933 Lahr
T +49 7821 586-392, F +49 7821 586-406
International.sales@zehndergroup.com
www.runtal.com

A member company of the Zehnder Group.

