

RUNTAL ANTEO

CHROM

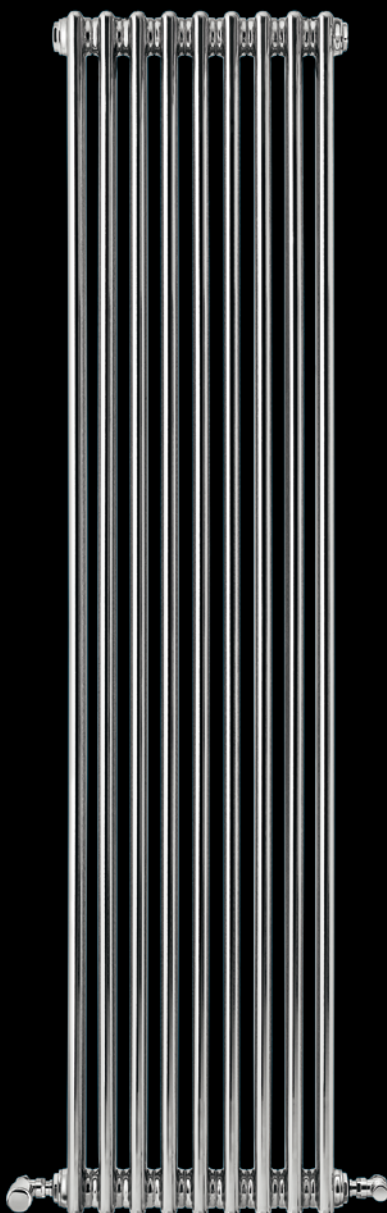

runtal

RUNTAL ANTEO CHROM. The original tube radiator, pure and simple. The patent application for this design was originally filed in 1930. Since that time, the flexible range of design options it offers has elevated its status to a true classic for living areas and workspaces alike. What's more, the chrome surface finish makes it a real design icon.

RUNTAL ANTEO CHROM. A new vision of the classic radiator.



RUNTAL ANTEO CHROM



TECHNICAL SPECIFICATIONS

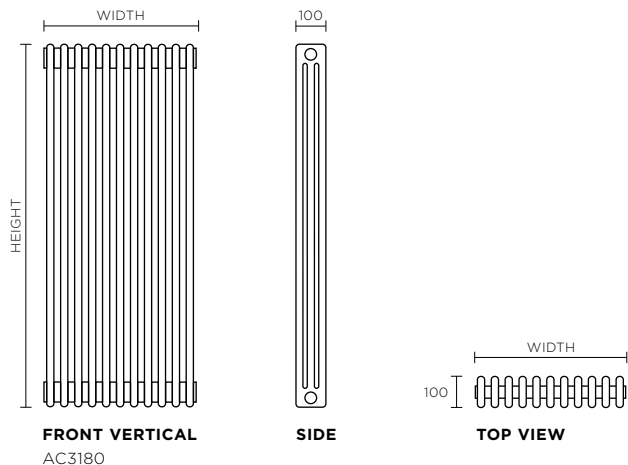

FRONT VERTICAL
AC3180

SIDE

TOP VIEW

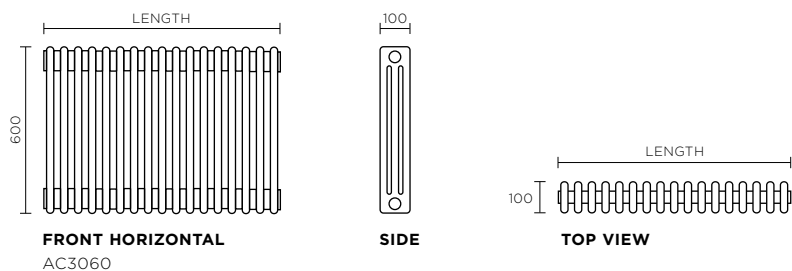

FRONT HORIZONTAL
AC3060

SIDE

TOP VIEW

PRODUCT DESCRIPTION

The classic RUNTAL ANTEO radiator is exceptionally versatile: thanks to the wide range of designs available, it can be used anywhere. Like the original version, the multi-layer coating process used for RUNTAL ANTEO CHROM gives the radiator an extremely long service life. The spacing between the heating tubes makes the radiator hygienic and very easy to clean. RUNTAL ANTEO CHROM is available with a chrome-plated surface in a range of different dimensions and is designed for connecting to the central heating.

TECHNICAL DATA

Name	AC3060 (horizontal) AC3180 (vertical)
Height	600/1800 mm
Width/length	AC3060: 541.5/820.5/1053 mm 11/17/22 elements AC3180: 216/355.5/448.5 mm 4/7/9 elements
Connections	For central heating, 2×½" for flow, return, lateral opposite ends, air vent
Valves	See Accessories price list
Colour	Chrome-plated
Heat output	500-1125 W
Standard	CE

ZEHNDER GROUP INTERNATIONAL SALES

Almweg 34, D-77933 Lahr

T +49 78 21 586-392, F +49 78 21 586-406

international.sales@zehndergroup.com

www.runtal.com

A member company of the Zehnder Group.

runtal